

## Standalone Linear Lithium Battery Charger With Thermal Regulation

### ■ INTRODUCTION

The SMC4106H is a complete constant-current/constant-voltage linear charger for single cell lithium rechargeable battery. No external sense resistor is needed, and no blocking diode is required due to the internal P-MOSFET architecture. Furthermore, the SMC4106H is specifically designed to work with in USB power specifications. Its low external component count makes the SMC4106H ideally suited for portable applications. Thermal feedback regulates the charge current to limit their temperature during high power operation or high ambient temperature. The charge current can be programmed externally with a single resistor. The SMC4106H automatically terminates the charge cycle when the charge current drops to 3/10<sup>th</sup> the programmed value after the final float voltage is reached. When the input supply (wall adapter or USB supply) is removed, the SMC4106H automatically enters a low power sleep mode, dropping the battery drain current to less than 2 $\mu$ A. The SMC4106H can be put into shutdown mode, reducing the supply current to 50 $\mu$ A. Other features include battery pack temperature monitor, under voltage lockout, automatic recharge and two status pins to indicate charging and charge termination.

### ■ APPLICATIONS

- Cellular phones, PDAs
- Portable Media Players
- Digital Still Cameras

### ■ FEATURES

- Charges Single Cell Lithium Battery Directly from USB Port or AC Adapter
- Input Voltage Range From 4.5V to 24V
- Input OVP: 6.5V
- No External MOSFET, Sense Resistor or Blocking Diode Required
- Preset 4.20V / 4.35V / 4.40V Charge Voltage
- Continuous Programmable Charge Current Up to 600mA
- Recharge Conditioning for Reviving Deeply Discharged Cells and Minimizing Heat Dissipation during Initial Stage of Charge
- Constant-Current/Constant-Voltage/Constant-Temp Operation with Thermal Regulation to Maximize Charge Rate Without Risk of Overheating
- Battery Reverse Protection
- Automatic Recharge
- Battery Temperature Sensing
- Charge state pairs of output, no battery and fault status display
- Charge Current Monitor Output for Gas Gauging
- Automatic Low Power Sleep Mode When Input Supply Voltage is Removed
- Soft-Start Limits Inrush Current
- Chip Enable Input

- Bluetooth & GPS Applications
- Mobile Internet Device
- Charging Docks and Cradles

## ■ ORDER INFORMATION

SMC4106H① ② ③ ④ ⑤

DESIGNATOR	SYMBOL	DESCRIPTION
①	A	Standard
②③④	Integer	Output Voltage: e.g.4.20V = ②:4, ③:2, ④:0
⑤	FB8	Package: DFN2X2-8

## ■ PIN CONFIGURATION (Top View)

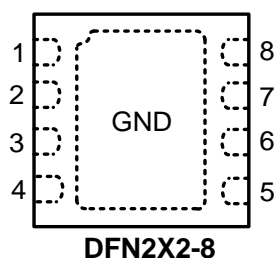

Table 1. Pin Description

PIN NO.	PIN NAME	FUNCTION
1	TEMP	<b>Battery temperature detection input.</b> Connecting TEMP pin to NTC the mistor's sensor output in Lithium ion battery pack. If the TEMP pin's voltage is less than 45% or greater than 80% of the input voltage $V_{CC}$ . This means the battery temperature is too high or too low, charging is suspended. If the TEMP pin's voltage level is between 45% and 80% of the input voltage $V_{CC}$ , battery fault state is released, and charging will resume. If the TEMP pin direct access GND, battery temperature detection canceled, the other charged functioning properly.
2	PROG	<b>Constant Charge Current Setting and Charge Current Monitor Pin.</b> The charge current is set by connecting a 1% accuracy metal film resistor $R_{PROG}$ from this pin to GND. When charging in precharge mode, the PROG pin voltage is regulated to 0.3V. When charging in constant-current mode, the PROG pin voltage is regulated to 1V. In all modes during charging, the voltage on PROG pin can be used to measure the charge current as the following formula: $BAT = (V_{PROG}/R_{PROG}) \times 1000.$
3	GND	<b>Ground Terminal.</b>
4	$V_{CC}$	<b>Positive Input Supply Voltage.</b> $V_{CC}$ is the power supply to the internal circuit. $V_{CC}$ should be bypassed with at least a 4.7 $\mu$ F capacitor. When $V_{CC}$ drops to within 80mv of the BAT pin voltage or $V_{CC} > V_{OVP}$ , SMC4106H enters low power sleep mode, dropping BAT pin's current to less than 2 $\mu$ A.
5	BAT	<b>Charger Power Stage Current Output and Battery Voltage Sense Input.</b> BAT pin provides charge current to the battery and regulates the final float voltage. An internal precision resistor divider from this pin sets the float voltage which is disconnected in shut down mode. Connect the positive terminal of the battery to BAT pin. By pass BAT to GND with 10 $\mu$ F to 47 $\mu$ F capacitor. BAT pin draws less than 2 $\mu$ A current in chip disable mode or in sleep mode.
6	$\overline{DONE}$	<b>Open-Drain Charge termination Status Output.</b> In charge termination status, $\overline{DONE}$ is pulled low by an internal switch; Otherwise $\overline{DONE}$ pin is in high impedance state.
7	$\overline{CHRG}$	<b>Open Drain Charge Status Output.</b> When the battery is being charged, the $\overline{CHRG}$ pin is pulled low by an internal switch, otherwise $\overline{CHRG}$ pin is in high impedance state.
8	CE	<b>Chip Enable Input.</b> A high input will put the device in the normal operating mode. Pulling the CE pin to low level will put the SMC4106H into disable mode. The CE pin can be driven by TTL or CMOS logic level. The CE pin is high impedance with internal 1M $\Omega$ Pull-up Resistor in the suspended state.
9	Thermal PAD	<b>Exposed Paddle (bottom).</b> This pin should be soldered to the PCB ground as close as to the device for electrical contact and rated thermal performance.

■ BLOCK DIAGRAM

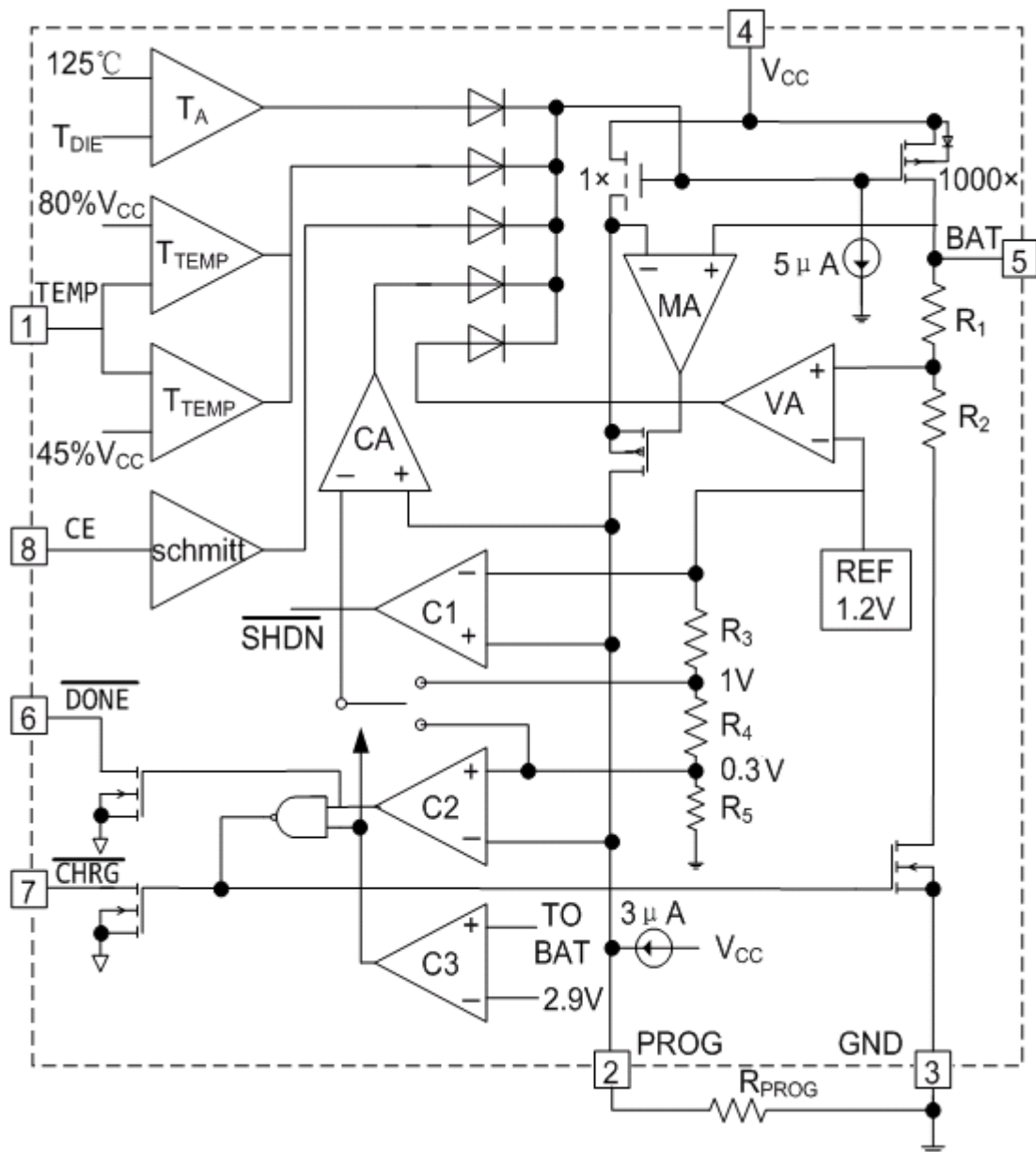

Figure 1 Functional Block Diagram

## ■ ABSOLUTE MAXIMUM RATINGS<sup>(1)</sup>

(Unless otherwise specified,  $T_A = 25^\circ\text{C}$ )

PARAMETER	SYMBOL	RATINGS	UNITS
Input Supply Voltage <sup>(2)</sup>	$V_{CC}$	-0.3 ~ 28	V
PROG Pins Voltage <sup>(2)</sup>		-0.3 ~ 7	
BAT Pin Voltage <sup>(2)</sup>		-5 ~ 12	
CE, $\overline{\text{CHRG}}$ , $\overline{\text{DONE}}$ , TEMP Pins Voltage <sup>(2)</sup>	$I_{\overline{\text{CHRG}}}$ , $I_{\overline{\text{DONE}}}$	-0.3 ~ 28	
BAT Short-Circuit Duration	-	Continuous	-
BAT Pin Output Current (Continuous)	$I_{\text{BAT}}$	800	mA
Output sink current		10	mA
Power dissipation	$P_D$	800	mW
Operating Ambient Temperature Range <sup>(3)</sup>	$T_A$	-40 ~ 85	$^\circ\text{C}$
Junction Temperature	$T_J$	-40 ~ 150	$^\circ\text{C}$
Storage Temperature	$T_{\text{stg}}$	-40 ~ 125	$^\circ\text{C}$
Lead Temperature (Soldering, 10s)	$T_{\text{solder}}$	260	$^\circ\text{C}$
ESD rating <sup>(4)</sup>	HBM	2000	V
	MM	200	V

(1) Stresses beyond those listed under absolute maximum ratings may cause permanent damage to the device. These are stress ratings only, and functional operation of the device at these or any other conditions beyond those indicated under recommended operating conditions is not implied. Exposure to absolute-maximum-rated conditions for extended periods may affect device reliability.

(2) All voltages are with respect to network ground terminal.

(3) Specifications over the  $-40^\circ\text{C}$  to  $85^\circ\text{C}$  operating temperature range are assured by design, characterization and correlation with statistical process controls.

(4) The human body model is a 100pF capacitor discharged through a 1.5k $\Omega$  resistor into each pin. The machine model is a 200pF capacitor discharged directly into each pin.

## ■ RECOMMENDED OPERATING CONDITIONS

PARAMETER	SYMBOL	MIN	MAX	UNITS
Input voltage range <sup>(5)</sup>	$V_{CC}$	4.5	24	V
BAT Pin Output Current (Continuous)	$I_{\text{BAT}}$		600 <sup>(6)</sup>	mA
Fast-charge current programming resistor <sup>(7)</sup>	$R_{\text{PROG}}$	1.66	50	k $\Omega$

(5) If  $V_{CC}$  is between UVLO and 4.5V, and above the battery voltage, then the IC is active (can deliver some charge to the battery), but the IC will have limited or degraded performance (some functions may not meet data sheet specifications). The battery may be undercharged ( $V_{\text{FLOAT}}$  less than in the specification), but will not be overcharged ( $V_{\text{FLOAT}}$  will not exceed specification).

(6) The thermal regulation feature reduces charge current if the IC's junction temperature reaches  $125^\circ\text{C}$ ; Thus without a good thermal design the maximum programmed charge current may not be reached.

(7) Use a 1% tolerance metal film resistor for  $R_{\text{PROG}}$  to avoid issues with the  $R_{\text{PROG}}$  short test when using the maximum charge current setting.

## ■ ELECTRICAL CHARACTERISTICS

( $V_{CC} = 5V$ ,  $T_A = 25^\circ C$ , Test Circuit Figure2, unless otherwise specified)

PARAMETER	SYMBOL	CONDITIONS	MIN	TYP	MAX	UNITS
Input Standoff Voltage			24			V
Input Over-Voltage Protection Voltage	$V_{ovp}$	$V_{CC}$ Rising, Hys = 0.27V	6.1	6.5	6.9	V
Input Voltage Range for Charging			4.5		6.0	V
$V_{CC}$ Under voltage Lockout Threshold	$V_{UVL}$	$V_{CC}$ from Low to High		3.9		V
$V_{CC}$ Under voltage Lockout Hysteresis	$\Delta V_{UVL}$			150		mV
Input Supply Current	$I_{CC}$	Charge Mode, $R_{PROG} = 10K$		150	500	$\mu A$
		Standby Mode (Charge Terminated)		75	150	
		Shutdown Mode: $R_{PROG}$ Not Connected, $V_{CC} < V_{BAT}$ , or $V_{CC} < V_{UVL}$		50	100	
CE "High" Level Voltage	$V_{CEH}$		1.5		$V_{CC}$	V
CE "Low" Level Voltage	$V_{CEL}$				0.4	V
Trickle Charge Threshold	$V_{TRIKL}$	$R_{PROG} = 10K, V_{BAT}$ Rising		2.9		V
Trickle Charge Hysteresis	$\Delta V_{TRIKL}$	$R_{PROG} = 10K$		100		mV
Trickle Charge Current	$I_{TRIKL}$	$R_{PROG} = 2K$	135	150	165	mA
BAT Pin Current	$I_{BAT}$	$R_{PROG} = 2K$ , Current Mode ( $V_{BAT} = 4.0V$ )	450	500	550	mA
		Standby Mode, $V_{BAT} = V_{FLOAT}$	0	-2	-6	$\mu A$
		Shutdown Mode ( $R_{PROG}$ Not Connected)		$\pm 1$	$\pm 2$	
		Sleep Mode, $V_{CC} = 0V$			-1	
PROG Pin Voltage	$V_{PROG}$	$R_{PROG} = 1K$ , Current Mode	0.9	1.0	1.1	V
PROG Pin Pull-Up Current	$I_{PROG}$			3		$\mu A$

## ■ ELECTRICAL CHARACTERISTICS(continued)

( $V_{CC} = 5V$ ,  $T_A = 25^\circ C$ , Test Circuit Figure2, unless otherwise specified)

PARAMETER	SYMBOL	CONDITIONS	MIN	TYP	MAX	UNITS
Regulated Output (Float) Voltage	$V_{FLOAT}$	$I_{BAT} = 45mA$ , $R_{PROG} = 10K$	4.158	4.200	4.250	V
			4.300	4.350	4.400	V
			4.350	4.400	4.450	V
3C/10 Termination Current Threshold	$I_{TERM}$	$R_{PROG} = 2K$		0.3		mA/mA
Termination Comparator Filter Time	$t_{Term}$	$I_{BAT}$ Falling Below $I_{TERM}$	0.3	0.8	2.0	mS
Recharge Battery Threshold	$\Delta V_{RECHG}$	$V_{FLOAT} - V_{RECHG}$		150		mV
Recharge Comparator Filter Time	$t_{RECHARGE}$	$V_{BAT}$ High to Low	0.3	0.8	2.0	mS
$V_{CC} - V_{BAT}$ Lockout Threshold	$A_{MSD}$	$V_{CC}$ from Low to High		100		mV
		$V_{CC}$ from High to Low		80		mV
$\overline{CHRG}$ Pin Voltage	$V_{CHRG}$	$I_{CHRG} = 5mA$		0.3	0.6	V
$\overline{DONE}$ Pin Voltage	$V_{DONE}$	$I_{DONE} = 5mA$		0.3	0.6	V
TEMP High Shift Voltage Level			76	80	82	% $V_{CC}$
TEMP Low Shift Voltage Level			43	45	49	
Soft-Start Time	$t_{SS}$	$I_{BAT} = 0$ to $I_{BAT} = 1000V/R_{PROG}$		20		$\mu S$
Power FET "ON" Resistance (Between $V_{CC}$ and BAT)	$R_{ON}$	$I_{BAT} = 600mA$		1000		$m\Omega$
Junction Temperature in Constant Temperature Mode	$T_{J(REG)}$			140		$^\circ C$

## ■ TYPICAL APPLICATION CIRCUIT

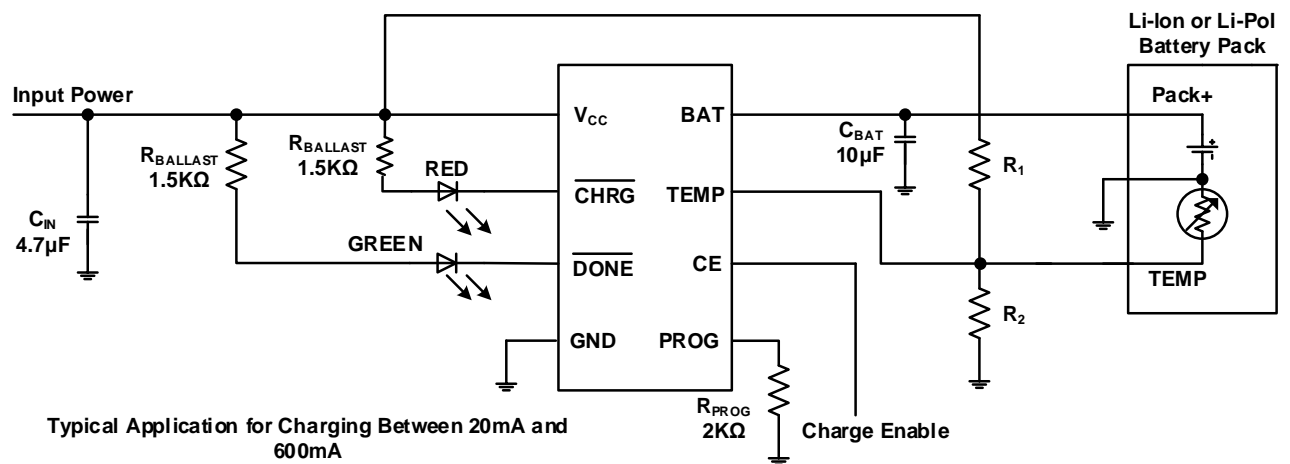

Figure2 Standard Application Circuit

## ■ FUNCTIONAL DESCRIPTION

The SMC4106H series are highly integrated Li-Ion or Li-Pol linear battery chargers, targeted at space-limited portable applications. It operates from either a USB port or Wall Adapter and charges a single-cell Li-Ion or Li-Pol battery with up to 600mA of charge current.

The charge current is programmable using external components ( $R_{PROG}$  resistor). The charge process starts when an external input power is connected to the system,  $V_{CC} > V_{UVL}$ ,  $V_{CC} > V_{BAT} + V_{(SLP\_EXIT)}$ , the charger is enabled by the  $R_{PROG}$  resistor connected and the battery voltage is below the recharge threshold,  $V_{BAT} < V_{RECHG}$ .

When the charger is enabled two control loops modulate the battery switch drain to source impedance to limit the BAT pin current to the programmed charge current value (charge current loop) or to regulate the BAT pin voltage to the programmed charge voltage value (charge voltage loop). If  $V_{BAT} < V_{TRIKL}$  (2.9V typical), the BAT pin current is internally set to 3/10th of the programmed fast-charge current value in current regulation mode.

The SMC4106H series provide battery charge status via **CHRG & DONE** status

pins. **CHRG & DONE** Pins are internally connected to an N-channel open drain MOSFET.

The open drain status output that is not used should be tied to ground.

The following table lists the indicator status and its corresponding charging state.

Table 1. Charge Status Indicator <sup>(1)</sup>

Charge State Description	$\overline{\text{CHRG}}$	$\overline{\text{DONE}}$
Preconditioning-Current Mode (Trickle) Charge	ON	HI-Z
Constant-Current Mode (Fast) Charge	ON	HI-Z
Constant-Voltage Mode (Taper) Charge, $I_{\text{BAT}} > I_{\text{TERM}}$	ON	HI-Z
Charge Termination ( $I_{\text{BAT}} < I_{\text{TERM}}$ , Charge Done)	HI-Z	ON
Power Down(Under voltage Lockout) Mode	HI-Z	HI-Z
Sleep Mode ( $V_{\text{UVL}} < V_{\text{CC}} < V_{\text{BAT}} + V_{\text{(SLP\_EXIT)}}$ , or the $V_{\text{CC}}$ is removed)	HI-Z	HI-Z
Shutdown Mode(PROG pin floating)	HI-Z	HI-Z
OVP Mode ( $V_{\text{CC}} > V_{\text{OVP}}$ )	HI-Z	HI-Z
No battery with Charge Enabled	FLASH Rate depends on $C_{\text{BAT}}$	FLASH
Fault Condition (Battery Short Circuit)	ON	HI-Z
Fault TEMP( $5\%V_{\text{CC}} < V_{\text{TEMP}} < 45\%V_{\text{CC}}$ $\ V_{\text{TEMP}} > 80\%V_{\text{CC}}$ )	HI-Z	HI-Z

(1)Pulse loading on the BAT pin may cause the IC to cycle between done and charging states (LEDs Flashing)



■ TYPICAL PERFORMANCE CHARACTERISTICS

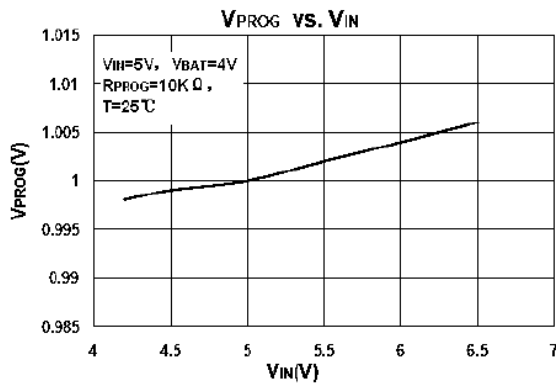

Figure 3

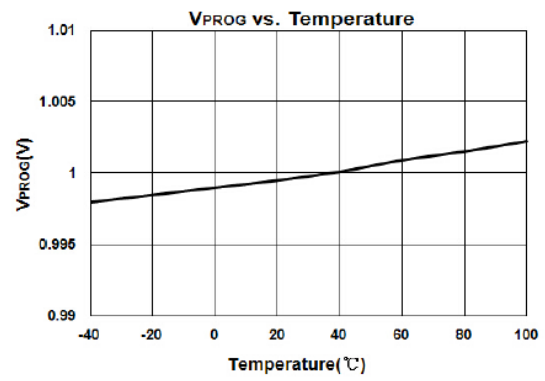

Figure 4

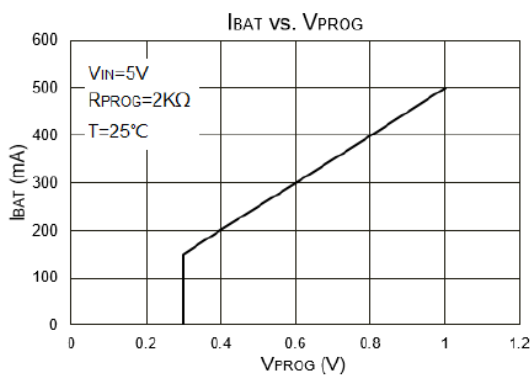

Figure 5

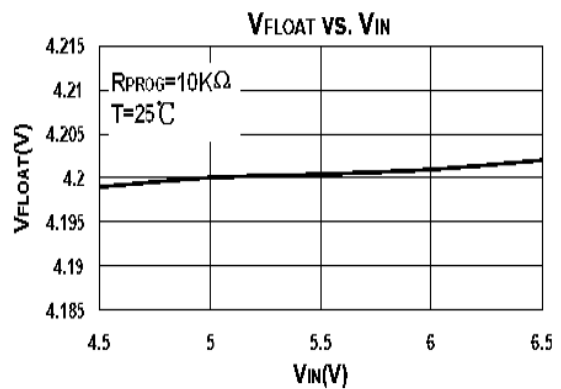

Figure 6

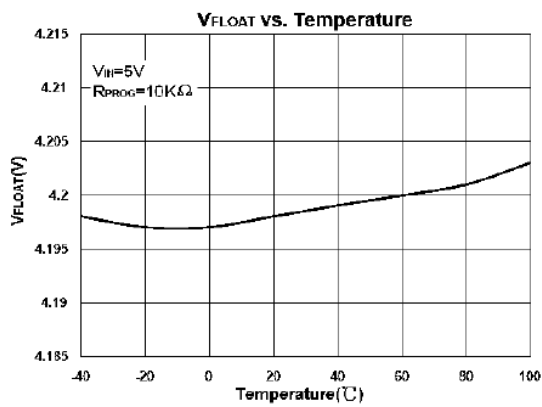

Figure 7

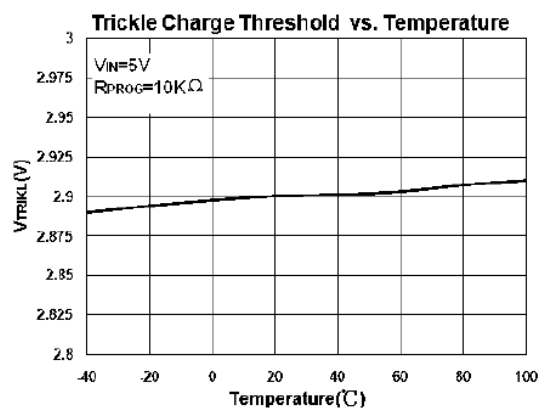
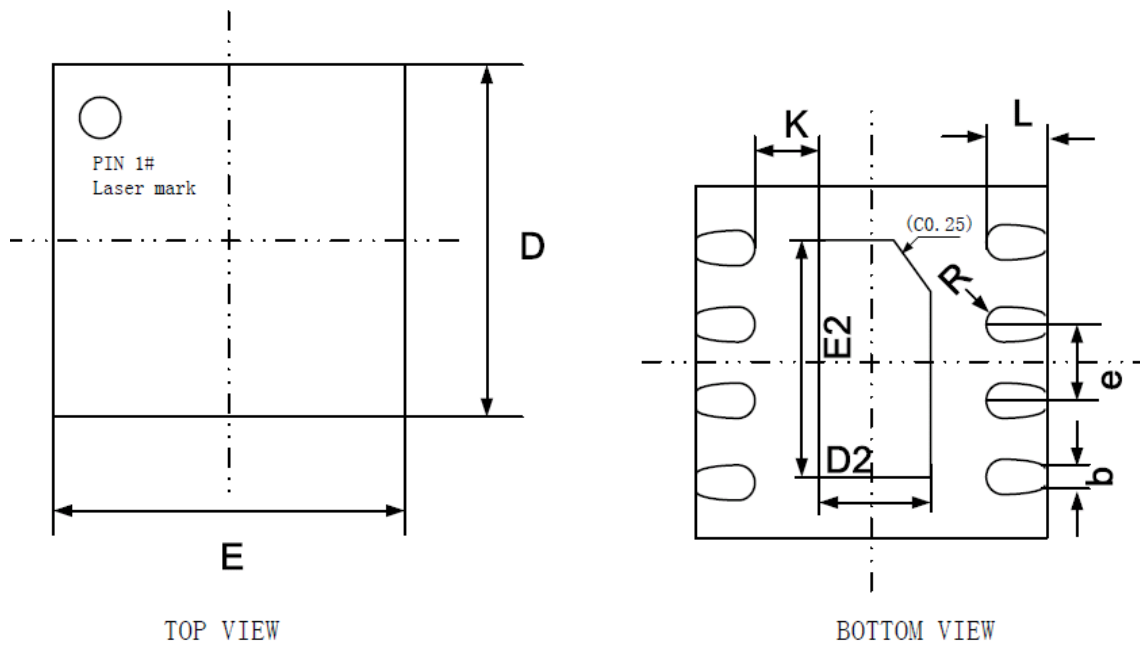

Figure 8

## ■ PACKAGING INFORMATION

### ● DFN2X2-8 Package Outline Dimensions



TOP VIEW

BOTTOM VIEW

SIDE VIEW

SYMBOL	Dimensions In Millimeters		
	MIN	NOM	MAX
A	0.70	0.75	0.80
A1	0.00	0.02	0.05
A3	0.20REF		
b	0.15	0.20	0.25
D	1.90	2.00	2.10
E	1.90	2.00	2.10
D2	0.50	0.60	0.70
E2	1.10	1.20	1.30
e	0.40	0.50	0.60
K	0.20	-	-
L	0.30	0.35	0.40
R	0.09	-	-

© SMTES TECHNOLOGY PTE. LTD.

SMTES cannot assume responsibility for use of any circuitry other than circuitry entirely embodied in a SMTES product. No circuit patent license, copyrights or other intellectual property rights are implied. SMTES reserves the right to make changes to their products or specifications without notice. Customers are advised to obtain the latest version of relevant information to verify, before placing orders, that information being relied on is current and complete.