

■ INTRODUCTION

The SMV910 Series is a series of high-precision voltage detectors with a built-in delay time generator of fixed time. developed using CMOS process.

The detection voltage is fixed internally, with an accuracy of $\pm 2.0\%$. Internal oscillator and counter timer can delay the release signal without external parts, delay times 200 ms Two output forms, NMOS open-drain and CMOS output are available.

■ APPLICATIONS

- Memory battery back-up circuits
- Power-on reset circuits
- Power failure detection
- Power monitor for portable equipment such as notebook computers, digital cameras, PDA, and cellular phones.
- Constant voltage power monitors for cameras, video equipment and communication devices.
- Power monitor for microcomputers and reset for CPUs.

■ FEATURES

- Ultra-low current consumption: 0.9 μ A@3.5V(Typ.)
- High-precision detection voltage: $\pm 2.0\%$
- Hysteresis characteristics: $-V_{DET} \times 5\%$ (Typ.)
- Operating voltage range: 0.95V to 7.0V
- Detection voltage: 1.5V to 6.0V (10mV step)
- Delay time: 210 ms (Typ.)
- Output forms:
NMOS open-drain output (Active High)
CMOS output (Active High)

■ ORDER INFORMATION

SMV910 ①②③④⑤

DESIGNATOR	SYMBOL	DESCRIPTION
①	C	CMOS
	N	NMOS open drain
②③④	Integer	Detection Voltage (1.50V~6.00V), “④”elide when it is “0” e.g. 3.0V=②:3, ③:0 2.93V=②:2, ③:9, ④:3
⑤		Package: SOT-23-3
		Package: SOT-23-5
		Package: SOT-89-3
		Package: TO-92
		Package: SOT-343 (SC-82)
		Package: SOT-23-6
		Package: SOT-23

■ BLOCK DIAGRAMS

NMOS open-drain

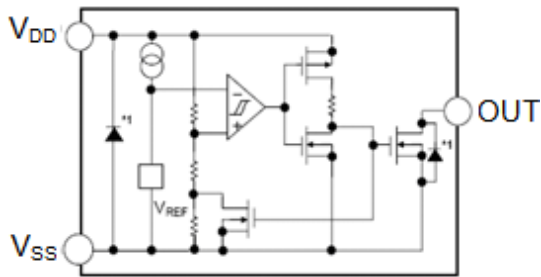

CMOS output

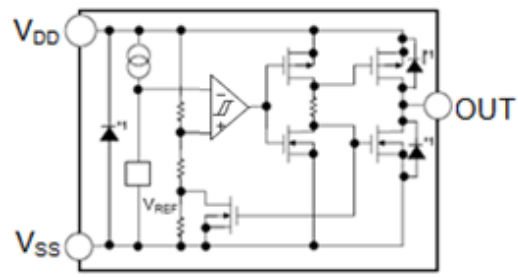

■ PIN CONFIGURATION

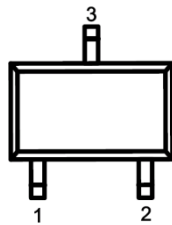

SMV910 Series (SOT-23-3/SOT-23)

PIN NO.	P	FUNCTION
1	V_{OUT}	Voltage detection output pin
2	V_{DD}	Voltage input pin
3	S V_{SS}	Ground

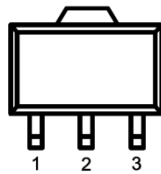

SMV910 Series (SOT-89-3)

PIN NO.	M	FUNCTION
1	V_{DD}	Voltage input pin
2	V_{OUT}	Voltage detection output pin
3	V_{SS}	Ground

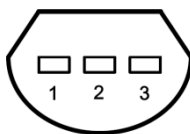

SMV910 Series (TO-92)

PIN NO.	T	FUNCTION
1	V_{OUT}	Voltage detection output pin
2	V_{DD}	Voltage input pin
3	V_{SS}	Ground

SMV910 Series (SOT-343)

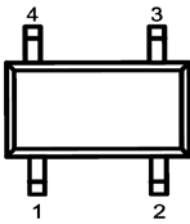

PIN NO.	N	FUNCTION
1	V_{OUT}	Voltage detection output pin
2	V_{DD}	Voltage input pin
3	NC	No Connection
4	V_{SS}	Ground

SMV910 Series (SOT-23-5)

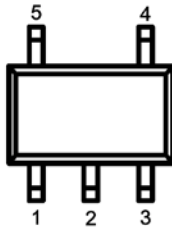

PIN NO.	MR	FUNCTION
1	V_{OUT}	Voltage detection output pin
2	V_{DD}	Voltage input pin
3	V_{SS}	Ground
4	NC	No connection
5	NC	No connection

SMV910 Series (SOT-23-6)

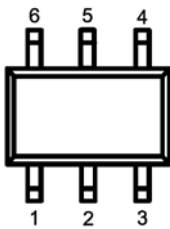

PIN NO	E	FUNCTION
1	NC	No Connection
2	V_{SS}	Ground
3	V_{OUT}	Voltage detection output pin
4	V_{DD}	Voltage input pin
5	NC	No Connection
6	NC	No Connection

■ ABSOLUTE MAXIMUM RATINGS

($T_A=25^\circ\text{C}$, unless otherwise specified)

PARAMETER	SYMBOL	RATINGS	UNITS
Power supply voltage	V_{DD}	$V_{SS} - 0.3 \sim V_{SS} + 8$	V
Output voltage	V_{OUT}	$V_{SS} - 0.3 \sim V_{SS} + 8$	V
Power dissipation	SOT-23-3	PD	400
	SOT-89-3		600
	TO-92		500
	SOT-343		250
Operating ambient temperature	T_{opr}	$-40 \sim +85$	$^\circ\text{C}$
Storage temperature	T_{stg}	$-55 \sim +150$	$^\circ\text{C}$
Soldering Temperature & Time	T_{solder}	$260^\circ\text{C}, 10\text{s}$	

■ ELECTRICAL CHARACTERISTICS

(T_A=25°C, unless otherwise specified)

PARAMETER	SYMBOL	CONDITIONS		MIN	TYP	MAX	UNITS
Detection voltage*1	-V _{DET}	—		-V _{DET(S)} ×0.98	-V _{DET(S)}	-V _{DET(S)} ×1.02	V
Hysteresis width	V _{HYS}	—		0.02× -V _{DET(S)}	0.05× -V _{DET(S)}	0.08× -V _{DET(S)}	V
Current consumption	I _{SS}	V _{DD} =-V _{DET} +0.5V	SMV910 C/N 20~26	—	1.0	3.0	μA
			SMV910 C/N 26~39	—	1.2	3.2	μA
			SMV910 C/N 39~60	—	1.5	3.5	μA
Operating voltage	V _{DD}	—		0.95	—	7	V
Output current	I _{OUT}	NMOS: V _{OUT} =0.5V V _{DD} =-V _{DET} +0.5V	SMV910 C/N 20~26	3.0	13.0	—	mA
			SMV910 C/N 26~39	3.0	15.0	—	mA
			SMV910 C/N 39~60	3.0	18.0	—	mA
		PMOS: V _{DD} -V _{OUT} =0.5V V _{DD} =-V _{DET} -0.5V	SMV910 C/N 20~26	1.5	4.0	—	mA
			SMV910 C/N 26~39	1.5	6.0	—	mA
			SMV910 C/N 39~60	1.5	8.0	—	mA
Leakage current	I _{LEAK}	Only for NMOS open-drain output products, V _{DD} =6.0V, V _{OUT} =6.0V		—	—	1.0	μA
temperature coefficient		T _a =-40°C ~+85°C		—	±120	±360	ppm/°C
Delay time	T _{PLH}			130	210	290	ms

*1. -V_{DET}: Actual detection voltage value, -V_{DET(S)}: Specified detection voltage value

■ FUNCTIONAL DESCRIPTION

1. When a voltage higher than the release voltage ($+V_{DET}$) is applied to the voltage input pin (V_{DD}), the voltage will gradually fall. When a voltage higher than the detect voltage ($-V_{DET}$) is applied to V_{DD} , output (V_{OUT}) will be equal to the ground voltage (V_{SS}).

Note that this also applies to N-channel open drain configurations.

2. When V_{DD} falls below $-V_{DET}$, V_{OUT} will be equal to the input at V_{DD} (detect state).

Note that high impedance exists at V_{OUT} with the N-channel open drain configuration. If the pin is pulled up, V_{OUT} will be equal to the pull up voltage.

3. When V_{DD} falls to a level below that of the minimum operating voltage (V_{MIN}) output will become unstable.

Because the output pin is generally pulled up with N-channel open drain configurations, output will be equal to pull up voltage.

4. When V_{DD} rises above the V_{SS} level (excepting levels lower than minimum operating voltage), V_{OUT} will be equal to V_{DD} until V_{DD} reaches the $+V_{DET}$ level.

5. Although V_{DD} will rise to a level higher than $+V_{DET}$, V_{OUT} maintains V_{DD} voltage level via the delay circuit.

6. Following transient delay time, V_{SS} will be output at V_{OUT} .

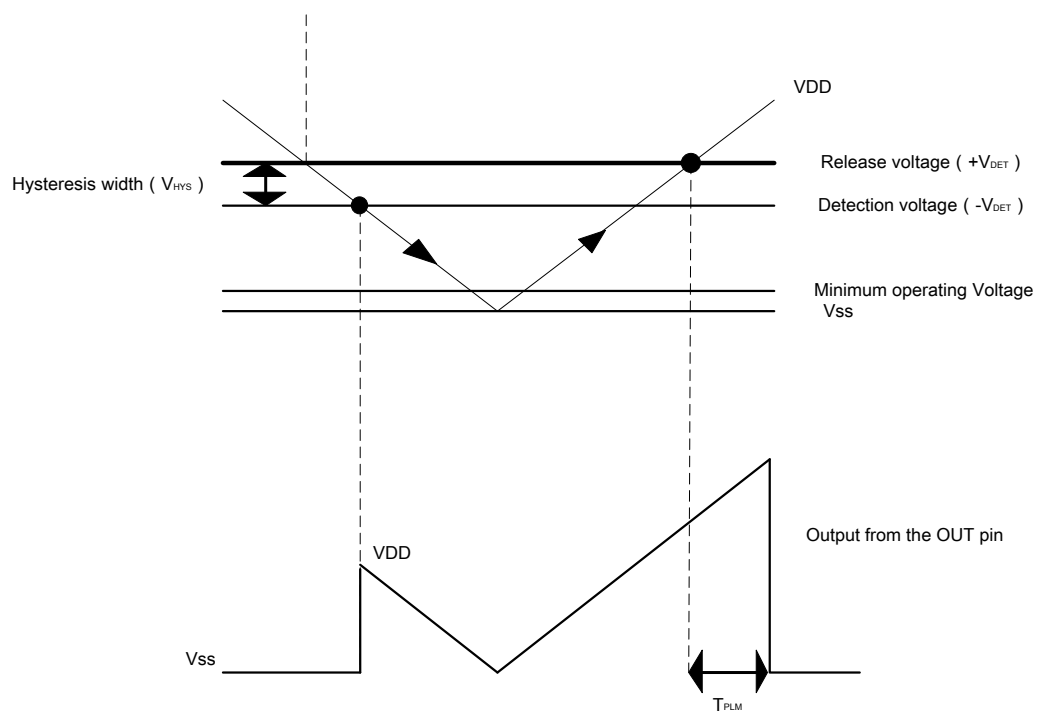

■ TYPICAL APPLICATION CIRCUITS

1、CMOS output:

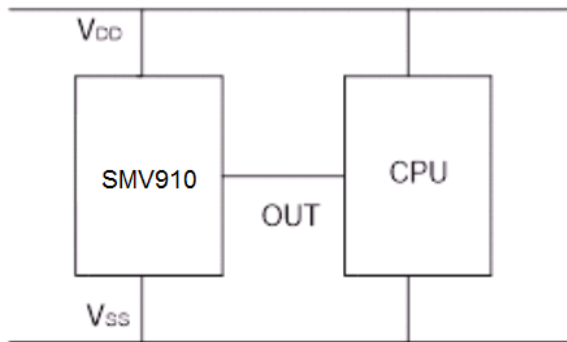

2、NMOS open-drain

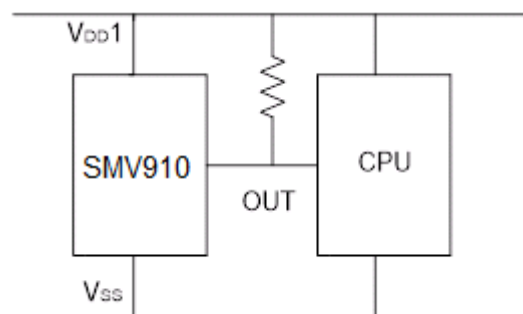
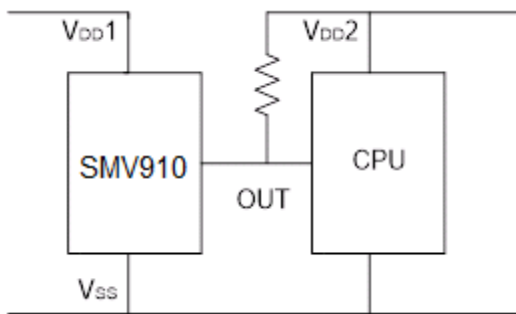

3. Forbidden Circuits

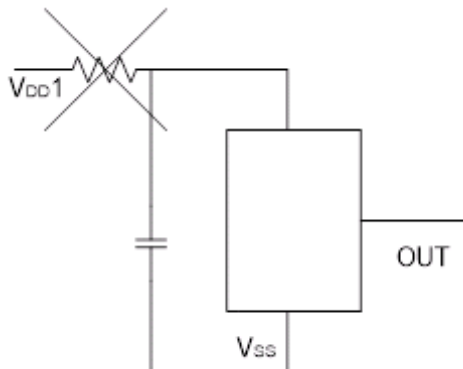

■ PACKAGING INFORMATION

● SOT-23

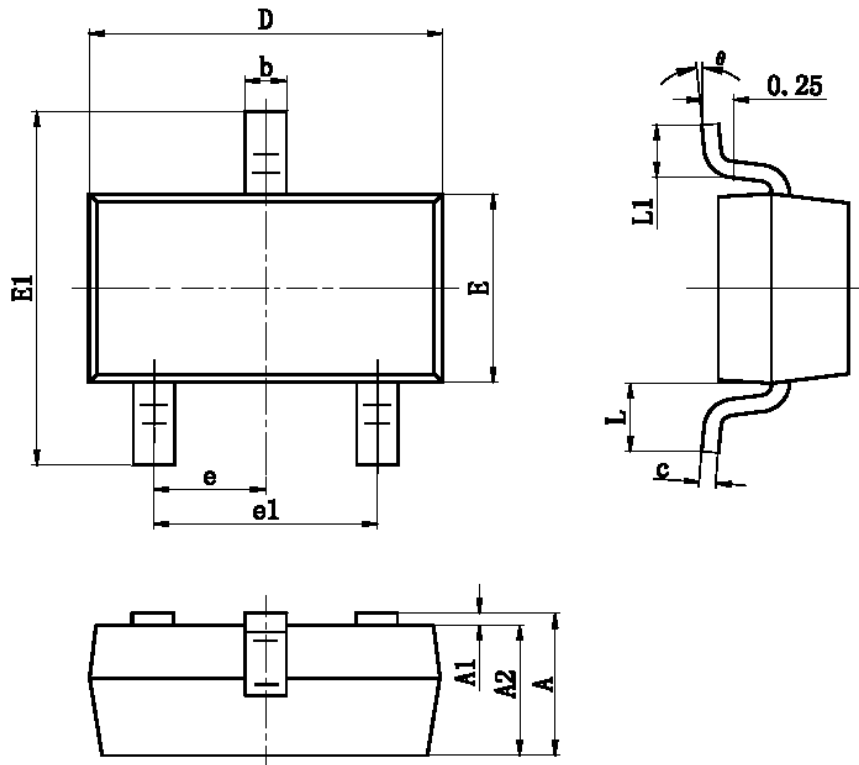

Symbol	Dimensions In Millimeters		Dimensions In Inches	
	Min	Max	Min	Max
A	0.900	1.150	0.035	0.045
A1	0.000	0.100	0.000	0.004
A2	0.900	1.050	0.035	0.041
b	0.300	0.500	0.012	0.020
c	0.080	0.150	0.003	0.006
D	2.800	3.000	0.110	0.118
E	1.200	1.400	0.047	0.055
E1	2.250	2.550	0.089	0.100
e	0.950 TYP		0.037 TYP	
e1	1.800	2.000	0.071	0.079
L	0.550 REF		0.022 REF	
L1	0.300	0.500	0.012	0.020
θ	0°	8°	0°	6°

• SOT-23-3

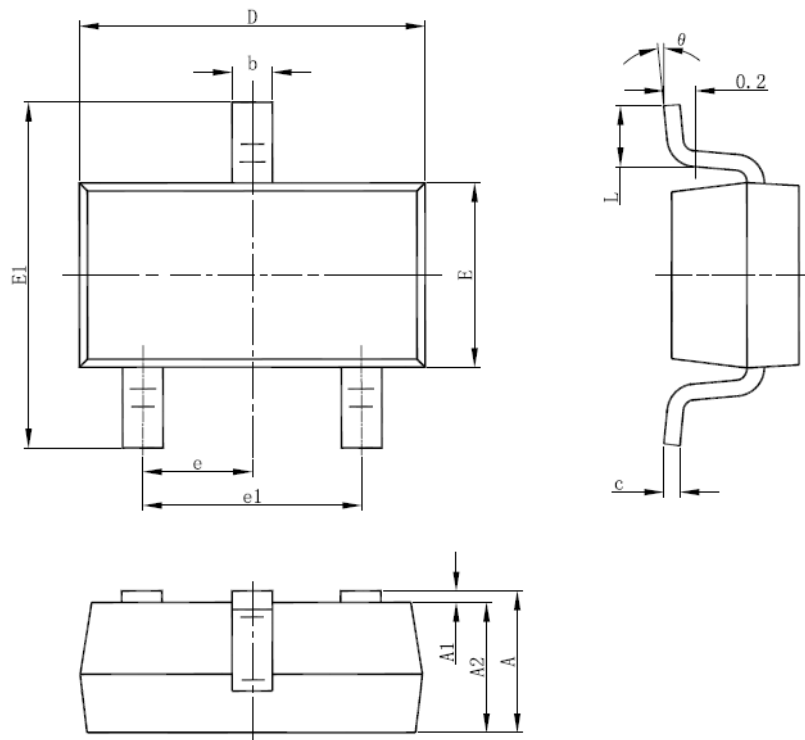

Symbol	Dimensions In Millimeters		Dimensions In Inches	
	Min	Max	Min	Max
A	1.050	1.250	0.041	0.049
A1	0.000	0.100	0.000	0.004
A2	1.050	1.150	0.041	0.045
b	0.300	0.500	0.012	0.020
c	0.100	0.200	0.004	0.008
D	2.820	3.020	0.111	0.119
E	1.500	1.700	0.059	0.067
E1	2.650	2.950	0.104	0.116
e	0.950(BSC)		0.037(BSC)	
e1	1.800	2.000	0.071	0.079
L	0.300	0.600	0.012	0.024
θ	0°	8°	0°	8°

• SOT-23-5

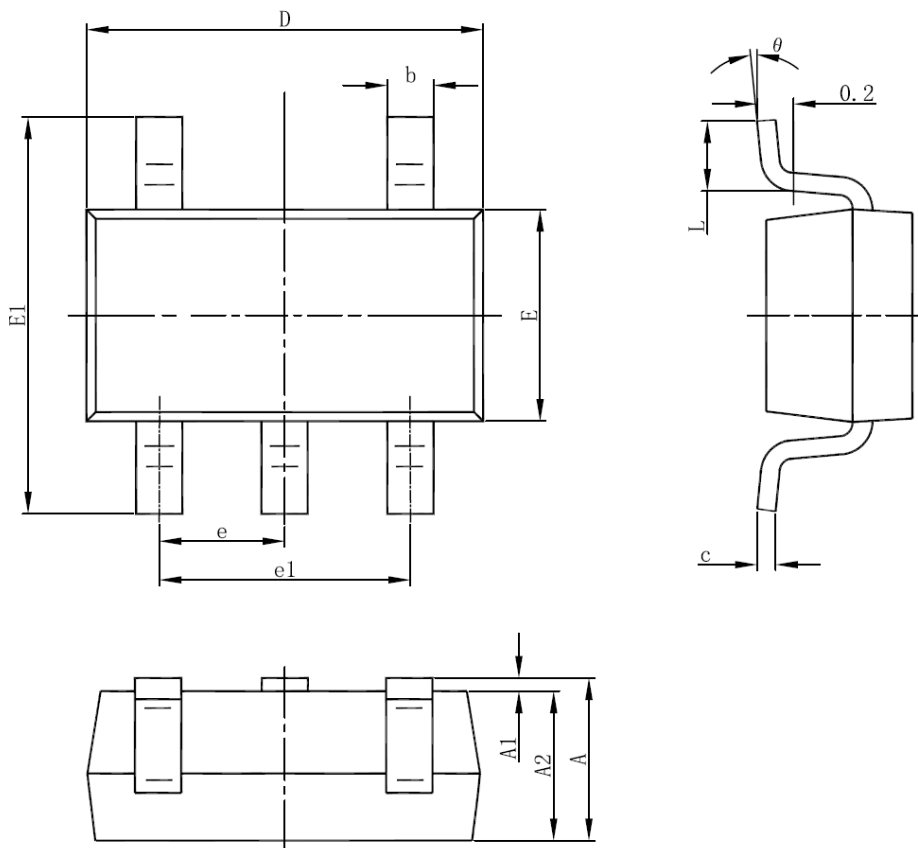

Symbol	Dimensions In Millimeters		Dimensions In Inches	
	Min	Max	Min	Max
A	1.050	1.250	0.041	0.049
A1	0.000	0.100	0.000	0.004
A2	1.050	1.150	0.041	0.045
b	0.300	0.500	0.012	0.020
c	0.100	0.200	0.004	0.008
D	2.820	3.020	0.111	0.119
E	1.500	1.700	0.059	0.067
E1	2.650	2.950	0.104	0.116
e	0.950(BSC)		0.037(BSC)	
e1	1.800	2.000	0.071	0.079
L	0.300	0.600	0.012	0.024
θ	0°	8°	0°	8°

• SOT-23-6

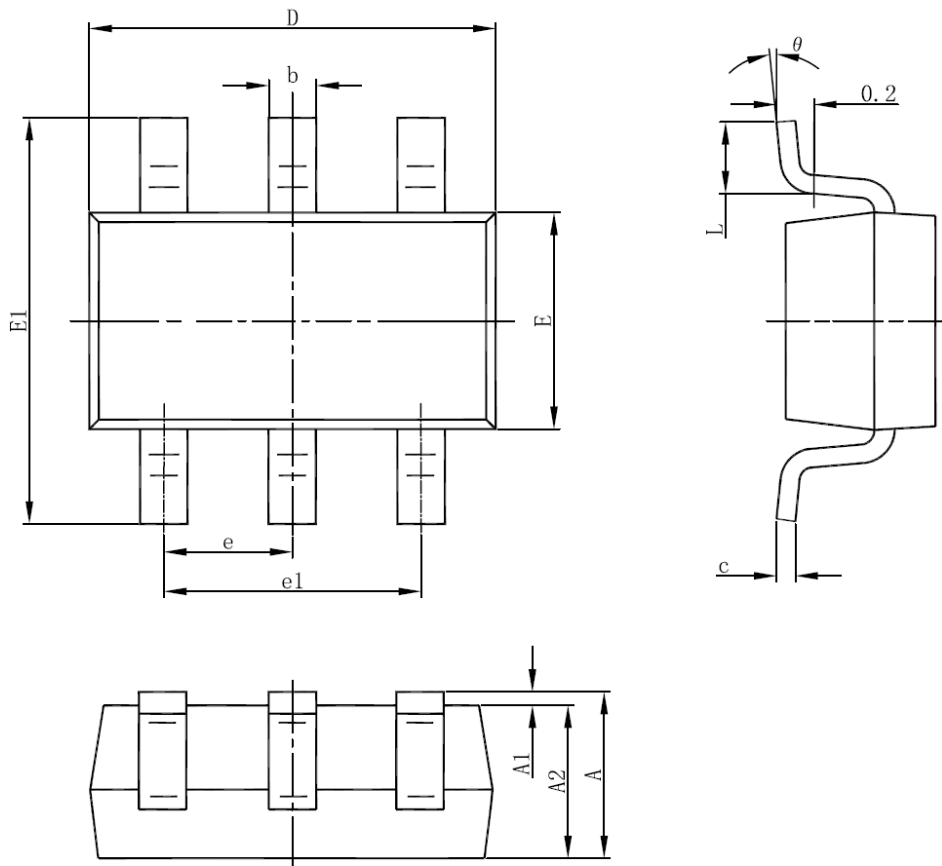

Symbol	Dimensions In Millimeters		Dimensions In Inches	
	Min	Max	Min	Max
A	1.050	1.250	0.041	0.049
A1	0.000	0.100	0.000	0.004
A2	1.050	1.150	0.041	0.045
b	0.300	0.500	0.012	0.020
c	0.100	0.200	0.004	0.008
D	2.820	3.020	0.111	0.119
E	1.500	1.700	0.059	0.067
E1	2.650	2.950	0.104	0.116
e	0.950(BSC)		0.037(BSC)	
e1	1.800	2.000	0.071	0.079
L	0.300	0.600	0.012	0.024
θ	0°	8°	0°	8°

• SOT-343

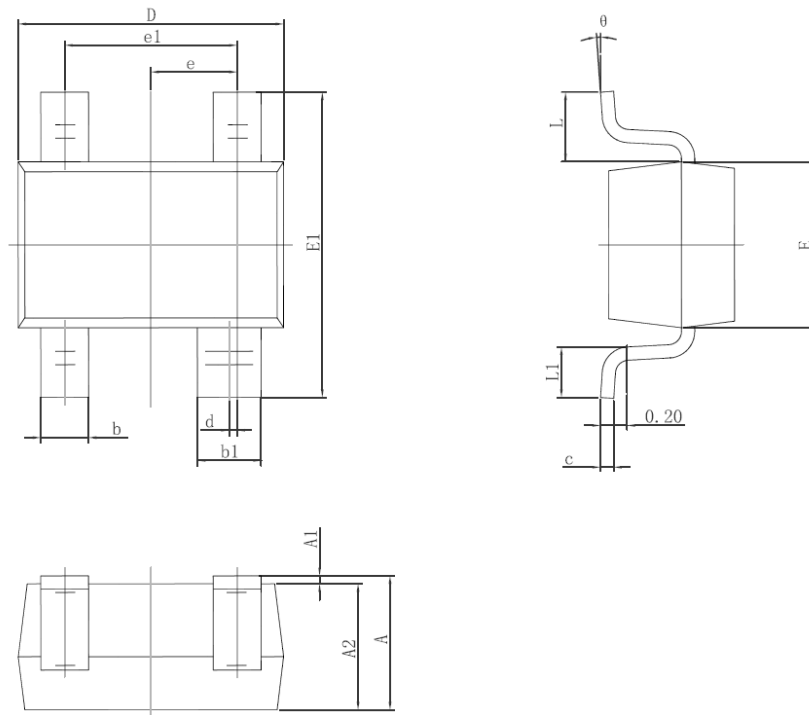

Symbol	Dimensions In Millimeters		Dimensions In Inches	
	Min.	Max.	Min.	Max.
A	0.900	1.100	0.035	0.043
A1	0.000	0.100	0.000	0.004
A2	0.900	1.000	0.035	0.039
b	0.250	0.400	0.010	0.016
b1	0.350	0.500	0.014	0.020
c	0.080	0.150	0.003	0.006
d	0.050 TYP.		0.002 TYP.	
D	2.000	2.200	0.079	0.087
E	1.150	1.350	0.045	0.053
E1	2.150	2.450	0.085	0.096
e	0.650 TYP.		0.026 TYP.	
e1	1.200	1.400	0.047	0.055
L	0.525 REF.		0.021 REF.	
L1	0.260	0.460	0.010	0.018
θ	0°	8°	0°	8°

• SOT-89-3

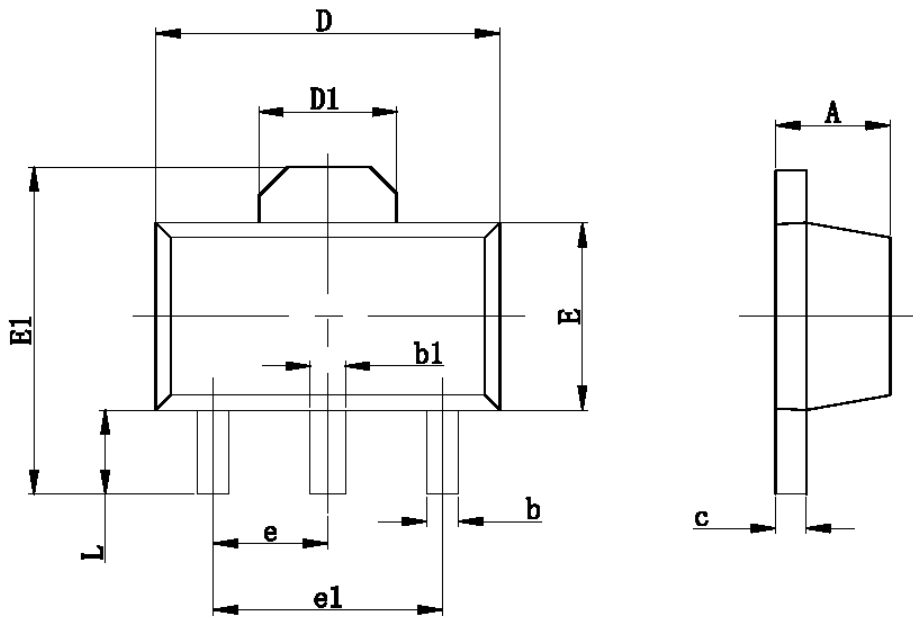

Symbol	Dimensions In Millimeters		Dimensions In Inches	
	Min	Max	Min	Max
A	1.400	1.600	0.055	0.063
b	0.320	0.520	0.013	0.197
b1	0.400	0.580	0.016	0.023
c	0.350	0.440	0.014	0.017
D	4.400	4.600	0.173	0.181
D1	1.550 REF		0.061 REF	
E	2.300	2.600	0.091	0.102
E1	3.940	4.250	0.155	0.167
e	1.500 TYP		0.060TYP	
e1	3.000 TYP		0.118TYP	
L	0.900	1.200	0.035	0.047

• TO-92

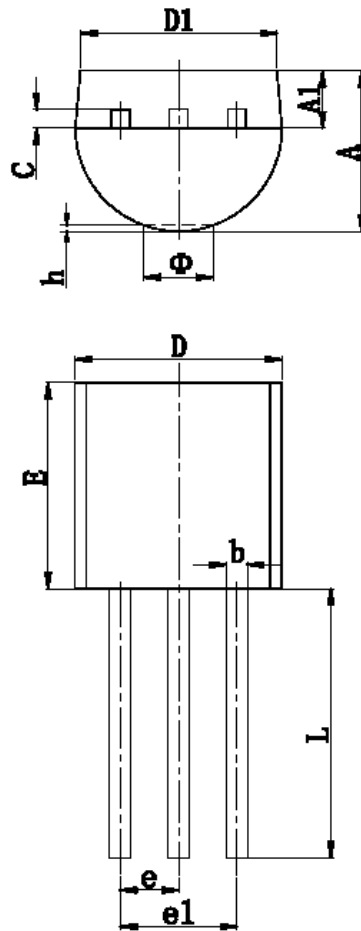

Symbol	Dimensions In Millimeters		Dimensions In Inches	
	Min	Max	Min	Max
A	3.300	3.700	0.130	0.146
A1	1.100	1.400	0.043	0.055
b	0.380	0.550	0.015	0.022
c	0.360	0.510	0.014	0.020
D	4.400	4.700	0.173	0.185
D1	3.430		0.135	
E	4.300	4.700	0.169	0.185
e	1.270 TYP		0.050 TYP	
e1	2.440	2.640	0.096	0.104
L	14.100	14.500	0.555	0.571
Φ		1.600		0.063
h	0.000	0.380	0.000	0.015

© SMTES TECHNOLOGY PTE. LTD.

SMTES cannot assume responsibility for use of any circuitry other than circuitry entirely embodied in a SMTES product. No circuit patent license, copyrights or other intellectual property rights are implied. SMTES reserves the right to make changes to their products or specifications without notice. Customers are advised to obtain the latest version of relevant information to verify, before placing orders, that information being relied on is current and complete.