

■ INTRODUCTION

The SMV808 Series is a series of high-precision voltage detectors developed using CMOS process. The detection voltage is fixed internally, with an accuracy of 2.0%. Two output forms, NMOS open-drain and CMOS output, are available.

■ APPLICATIONS

- Memory battery back-up circuits
- Power-on reset circuits
- Power failure detection
- Power monitor for portable equipment such as notebook computers, digital cameras, PDA, and cellular phones
- Constant voltage power monitors for cameras, video equipment and communication devices
- Power monitor for microcomputers and reset for CPUs

■ BLOCK DIAGRAMS

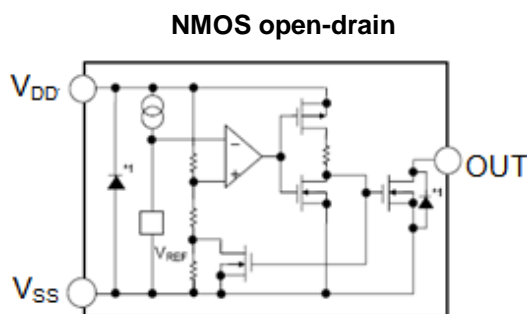

■ FEATURES

- Ultra-low current consumption: 0.9 μ A @ 3.5V(Typ.)
- High-precision detection voltage: \pm 2.0%
- Operating voltage range:0.95V ~7.0V
- Hysteresis characteristics: $-V_{DET}\times 5\%$ (Typ.)
- Detection voltage:1.5V ~ 6.0V(10mV step)
- Output forms:
NMOS open-drain output (Active Low)
CMOS output (Active Low)

■ ORDER INFORMATION

SMV808①②③④⑤

DESIGNATOR	SYMBOL	DESCRIPTION
①	C	CMOS
	N	NMOS open drain
②③④	Integer	Detection Voltage (1.50V~6.00V), “④”elide when it is “0” e.g. 3.0V=②:3, ③:0 2.93V=②:2, ③:9, ④:3
⑤	M/MA/MB/MR	Package: SOT-23,SOT-23-3/5
	N	Package: SOT-343(SC-82)
	P	Package: SOT-89-3
	T/TA	Package: TO-92

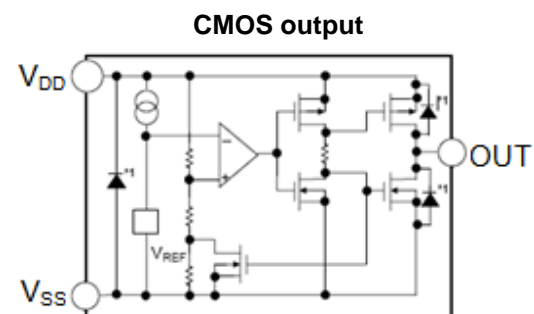

■ PIN CONFIGURATION

SOT-23-3
Top view

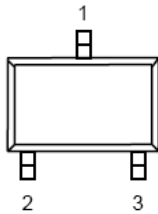

SMV808 Series (SOT-23-3/SOT-23)

PIN NO.	M	MA	MB	FUNCTION
1	V _{DD}	V _{DD}	V _{DD}	Voltage input pin
2	V _{OUT}	-	V _{OUT}	Voltage detection output pin
	-	V _{SS}	-	Ground
3	V _{SS}	-	V _{SS}	Ground
	-	V _{OUT}	-	Voltage detection output pin

SOT-23-5
Top view

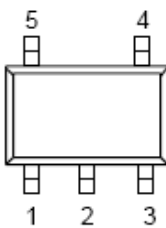

SMV808 Series (SOT-23-5)

PIN NO.	MR	FUNCTION
1	V _{OUT}	Voltage detection output pin
2	V _{DD}	Voltage input pin
3	S V _{SS}	Ground
4	M NC	No connection
5	NC	No connection

V

SOT-89-3
Top view

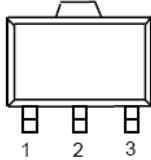

SMV808 Series (SOT-89-3)

PIN NO.	P	FUNCTION
1	V _{OUT}	Voltage detection output pin
2	V _{DD}	Voltage input pin
3	V _{SS}	Ground

SMV808 Series (TO-92)

TO-92
Bottom view



PIN NO.	T	TA	FUNCTION
1	V _{OUT}	-	Voltage detection output pin
	-	V _{DD}	Voltage input pin
2	V _{DD}	-	Voltage input pin
	-	V _{SS}	Ground
3	V _{SS}	-	Ground
	-	V _{OUT}	Voltage detection output pin

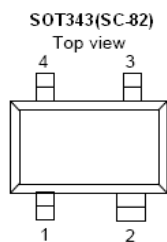

SMV808 Series (SOT-343)

PIN NO.	N	FUNCTION
1	V _{OUT}	Voltage detection output pin
2	V _{DD}	Voltage input pin
3	NC	No Connection
4	V _{SS}	Ground

■ ABSOLUTE MAXIMUM RATINGS

(T_A=25°C, unless otherwise specified)

PARAMETER		SYMBOL	RATINGS	UNITS
Power supply voltage		V _{DD}	V _{SS} - 0.3 ~ V _{SS} + 8	V
Output voltage		V _{OUT}	V _{SS} - 0.3 ~ V _{SS} + 8	V
Power dissipation	SOT-343	PD	250	mW
	SOT-23		250	mW
	SOT-23-3/5		400	mW
	TO-92		500	mW
	SOT-89-3		600	mW
Operating ambient temperature		T _{opr}	-40 ~ +85	°C
Storage temperature		T _{stg}	-55 ~ +150	°C
Soldering Temperature & Time		T _{solder}	260°C, 10s	°C
ESD rating	Human Body Model-(HBM)		2	KV
	Machine Model-(MM)		200	V

■ ELECTRICAL CHARACTERISTICS

(TA=25°C, unless otherwise specified)

PARAMETER	SYMBOL	CONDITIONS		MIN	TYP	MAX	UNITS
Detection voltage*1	$-V_{DET}$	—		$-V_{DET(S)}$ $\times 0.98$	$-V_{DET(S)}$	$-V_{DET(S)}$ $\times 1.02$	V
Hysteresis width	V_{HYS}	—		$0.02 \times$ $-V_{DET(S)}$	$0.05 \times$ $-V_{DET(S)}$	$0.08 \times$ $-V_{DET(S)}$	V
Current consumption	I_{SS}	$V_{DD} = -V_{DET} + 0.5V$	SMV808C/N 20~26	—	1.0	2.0	μA
			SMV808C/N 26~39	—	1.2	2.5	μA
			SMV808C/N 39~60	—	1.5	3.0	μA
Operating voltage	V_{DD}	—		0.95	—	7	V
Output current	I_{OUT}	NMOS: $V_{OUT} = 0.5V$ $V_{DD} = -V_{DET} - 0.5V$	SMV808C/N 20~26	3.0	13.0	—	mA
			SMV808C/N 26~39	3.0	15.0	—	mA
			SMV808C/N 39~60	3.0	18.0	—	mA
		PMOS: $V_{DD} - V_{OUT} = 0.5V$ $V_{DD} = -V_{DET} + 0.5V$	SMV808C/N 20~26	1.5	4.0	—	mA
			SMV808C/N 26~39	1.5	6.0	—	mA
			SMV808C/N 39~60	1.5	8.0	—	mA
Leakage current	I_{LEAK}	Only for NMOS open-drain output products, $V_{DD} = 8.0V, V_{OUT} = 8.0V$		—	—	1.0	μA
temperature coefficient		$T_A = -40^\circ C \sim +85^\circ C$		—	± 120	± 360	ppm/ $^\circ C$
Delay time	T_{PLH}				200		μs

*1. $-V_{DET}$: Actual detection voltage value, $-V_{DET(S)}$: Specified detection voltage value

■ FUNCTIONAL DESCRIPTION

1. When a voltage higher than the release voltage ($+V_{DET}$) is applied to the voltage input pin (V_{DD}), the voltage will gradually fall. When a voltage higher than the detect voltage ($-V_{DET}$) is applied to V_{DD} , output (V_{OUT}) will be equal to the input at V_{DD} . Note that high impedance exists at V_{OUT} with the N-channel open drain configuration. If the pin is pulled up, V_{OUT} will be equal to the pull up voltage.

2. When V_{DD} falls below $-V_{DET}$, V_{OUT} will be equal to the ground voltage (V_{SS}) level (detect state).

Note that this also applies to N-channel open drain configurations.

3. When V_{DD} falls to a level below that of the minimum operating voltage (V_{MIN}) output will become unstable.

Because the output pin is generally pulled up with N-channel open drain configurations, output will be equal to pull up voltage.

4. When V_{DD} rises above the V_{SS} level (excepting levels lower than minimum operating voltage), V_{OUT} will be equal to V_{SS} until V_{DD} reaches the $+V_{DET}$ level.

5. Although V_{DD} will rise to a level higher than $+V_{DET}$, V_{OUT} maintains ground voltage level via the delay circuit.

6. Following transient delay time, V_{DD} will be output at V_{OUT} .

Note that high impedance exists with the N-channel open drain configuration and that voltage will be dependent on pull up.

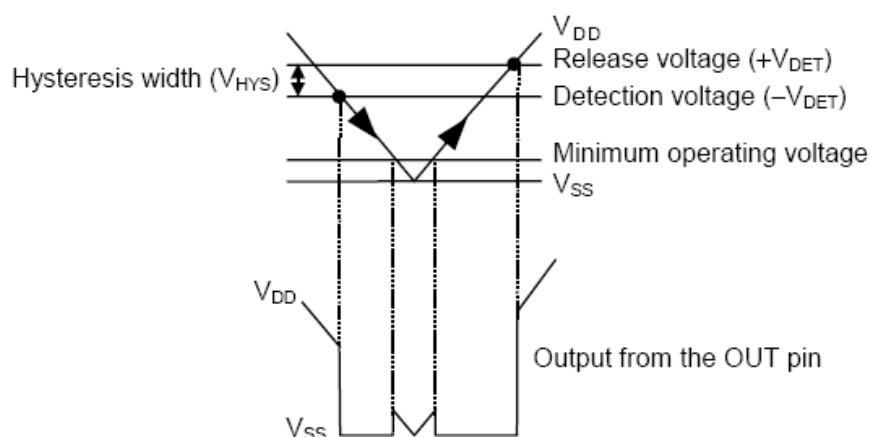

■ TYPICAL APPLICATION CIRCUITS

1、CMOS output:

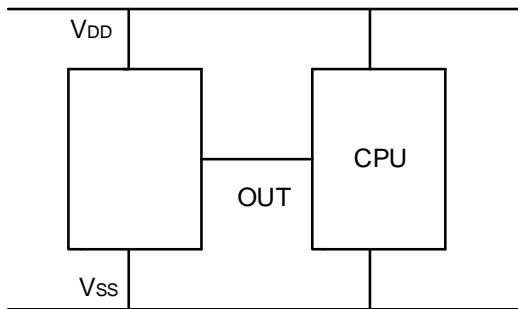

2、NMOS open-drain

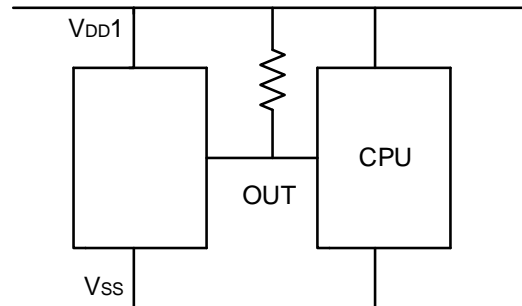
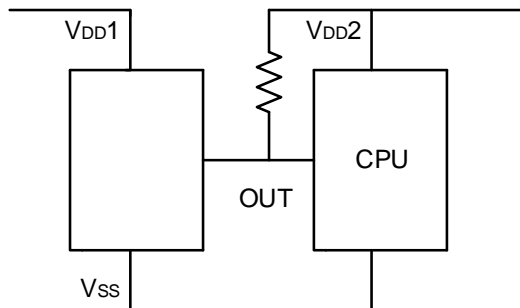

3. Forbidden Circuits

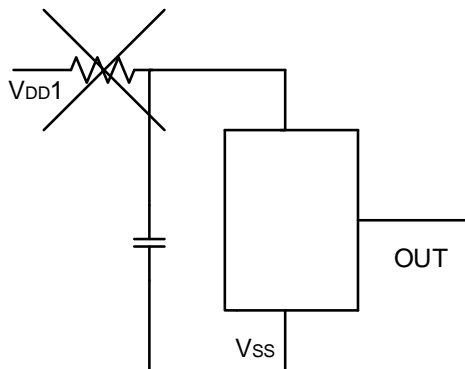

■ PACKAGING INFORMATION

● SOT-23

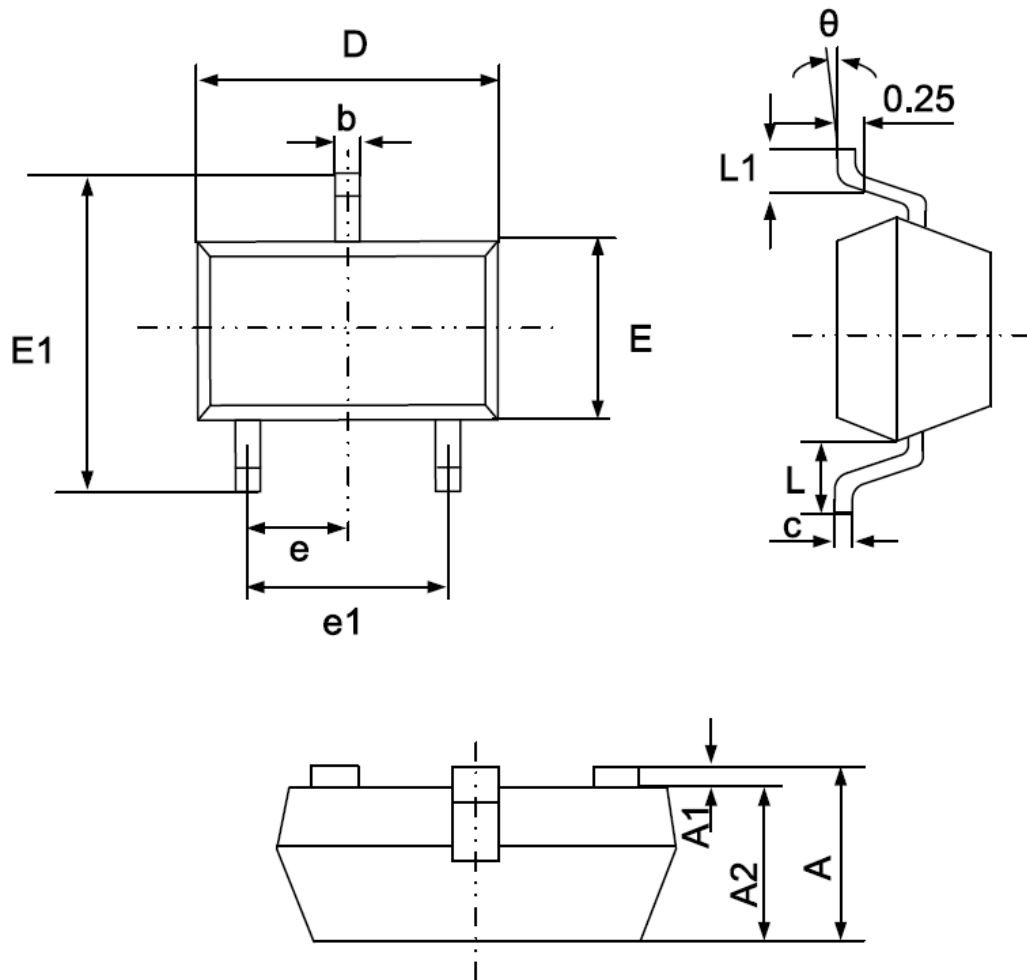

Symbol	Dimensions In Millimeters		Dimensions In Inches	
	Min.	Max.	Min.	Max.
A	0.900	1.150	0.035	0.045
A1	0.000	0.100	0.000	0.004
A2	0.900	1.050	0.035	0.041
b	0.300	0.500	0.012	0.020
c	0.080	0.150	0.003	0.006
D	2.800	3.000	0.110	0.118
E	1.200	1.400	0.047	0.055
E1	2.250	2.550	0.089	0.100
e	0.950(BSC)		0.037(BSC)	
e1	1.800	2.000	0.071	0.079
L	0.550REF		0.022REF	
L1	0.300	0.500	0.012	0.020
θ	0°	8°	0°	8°

• SOT-23-3

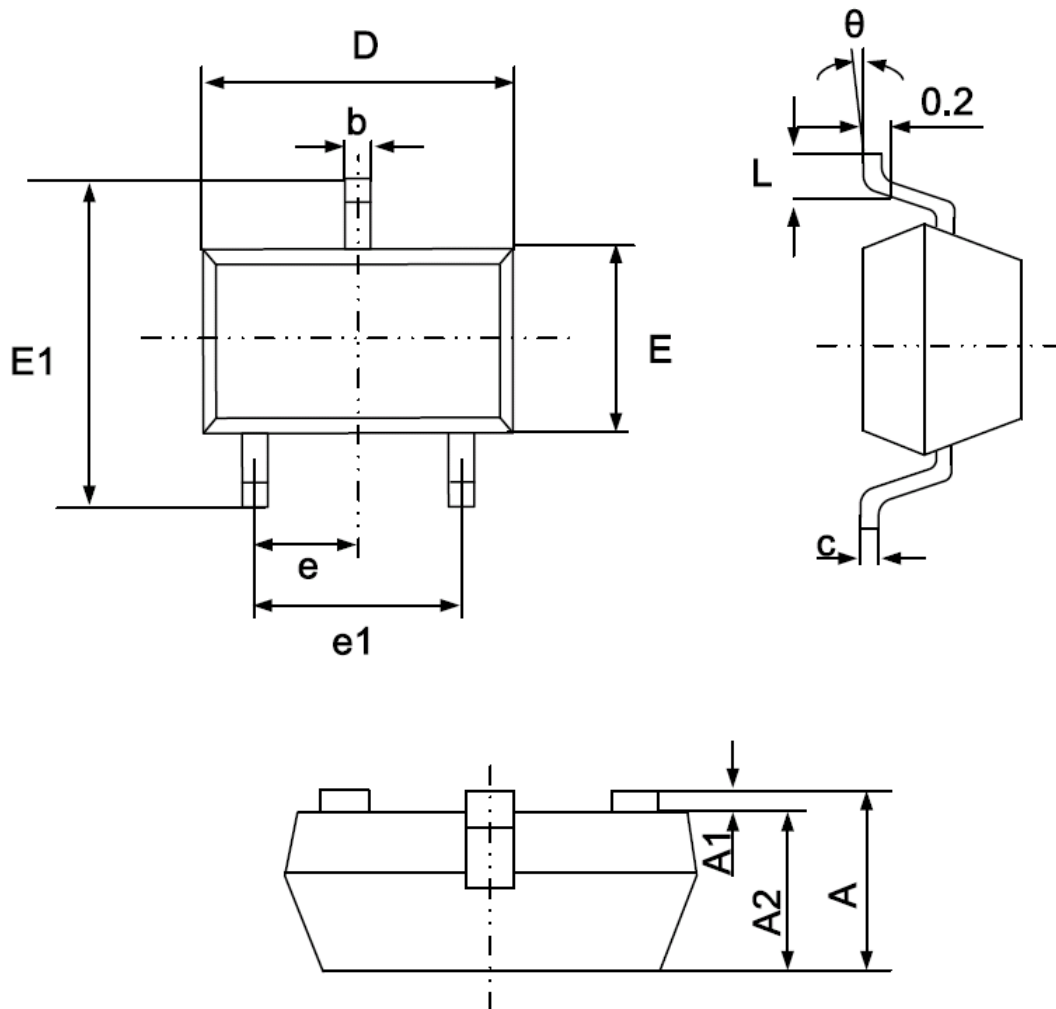

Symbol	Dimensions In Millimeters		Dimensions In Inches	
	Min.	Max.	Min.	Max.
A	1.050	1.250	0.041	0.049
A1	0.000	0.100	0.000	0.004
A2	1.050	1.150	0.041	0.045
b	0.300	0.500	0.012	0.020
c	0.100	0.200	0.004	0.008
D	2.820	3.020	0.111	0.119
E	1.500	1.700	0.059	0.067
E1	2.650	2.950	0.104	0.116
e	0.950(BSC)		0.037(BSC)	
e1	1.800	2.000	0.071	0.079
L	0.300	0.600	0.012	0.024
θ	0°	8°	0°	8°

• SOT-23-5

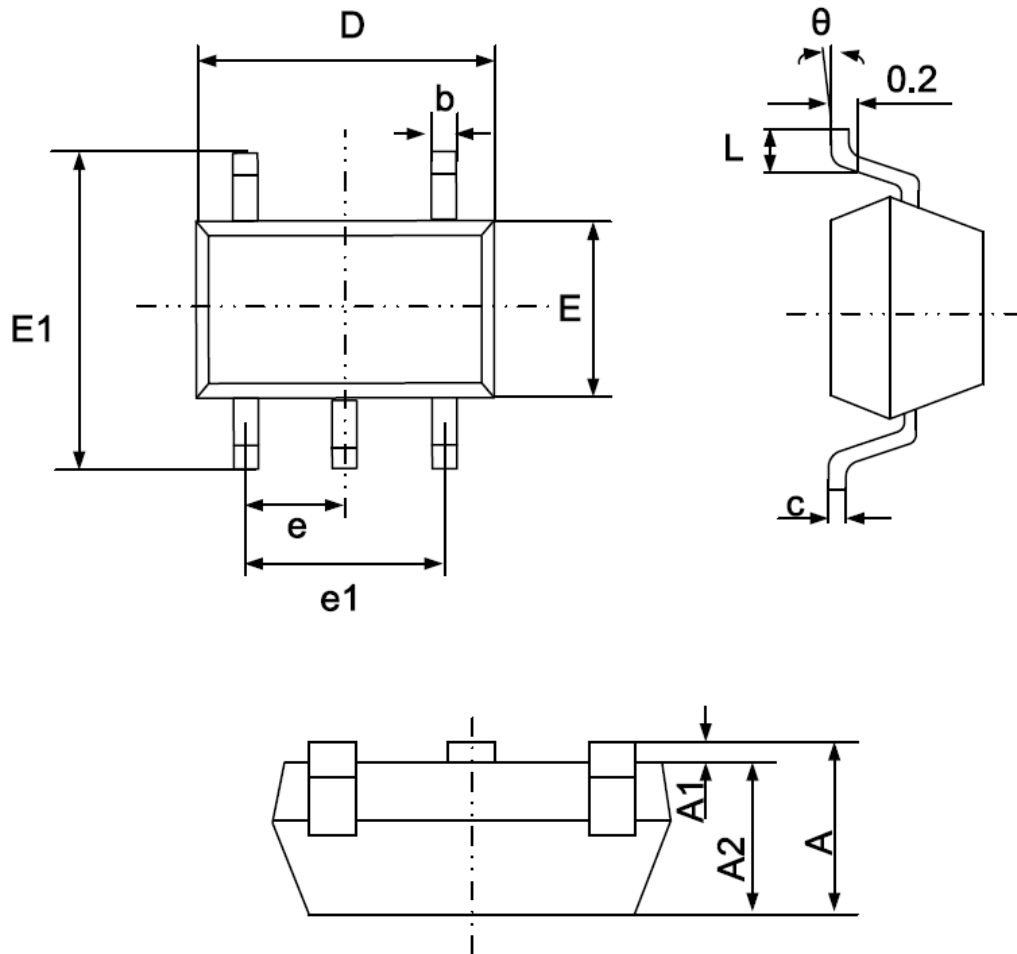

Symbol	Dimensions In Millimeters		Dimensions In Inches	
	Min.	Max.	Min.	Max.
A	1.050	1.250	0.041	0.049
A1	0.000	0.100	0.000	0.004
A2	1.050	1.150	0.041	0.045
b	0.300	0.500	0.012	0.020
c	0.100	0.200	0.004	0.008
D	2.820	3.020	0.111	0.119
E	1.500	1.700	0.059	0.067
E1	2.650	2.950	0.104	0.116
e	0.950(BSC)		0.037(BSC)	
e1	1.800	2.000	0.071	0.079
L	0.300	0.600	0.012	0.024
θ	0°	8°	0°	8°

• SOT-89-3

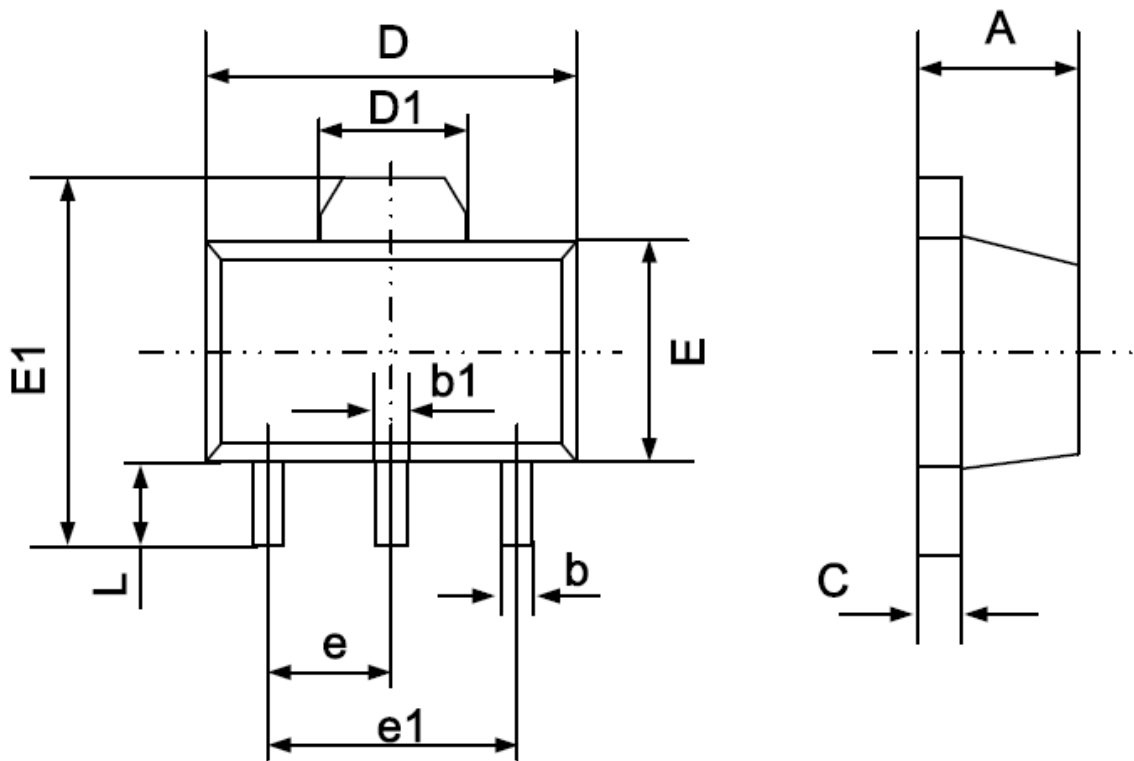

Symbol	Dimensions In Millimeters		Dimensions In Inches	
	Min.	Max.	Min.	Max.
A	1.400	1.600	0.055	0.063
b	0.320	0.520	0.013	0.020
b1	0.400	0.580	0.016	0.023
c	0.350	0.440	0.014	0.017
D	4.400	4.600	0.173	0.181
D1	1.550 REF		0.061 REF	
E	2.300	2.600	0.091	0.102
E1	3.940	4.250	0.155	0.167
e	1.500 TYP		0.060 TYP	
e1	3.000 TYP		0.118 TYP	
L	0.900	1.200	0.035	0.047

• TO-92

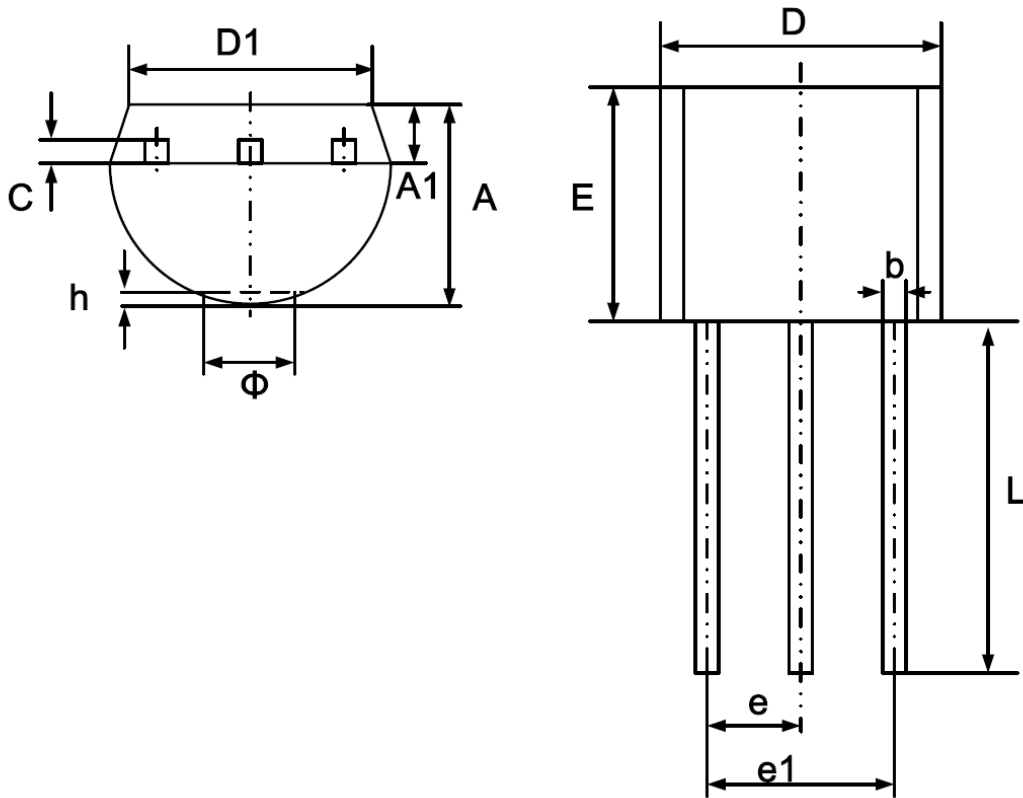

Symbol	Dimensions In Millimeters	
	Min.	Max.
A	3.300	3.800
A1	1.100	1.400
b	0.380	0.600
c	0.300	0.500
D	4.400	4.800
D1	3.430	
E	4.300	4.700
e	1.270 TYP	
e1	2.440	2.640
L	13.00	15.00
Φ		1.600
h	0.000	0.380

• SOT-343

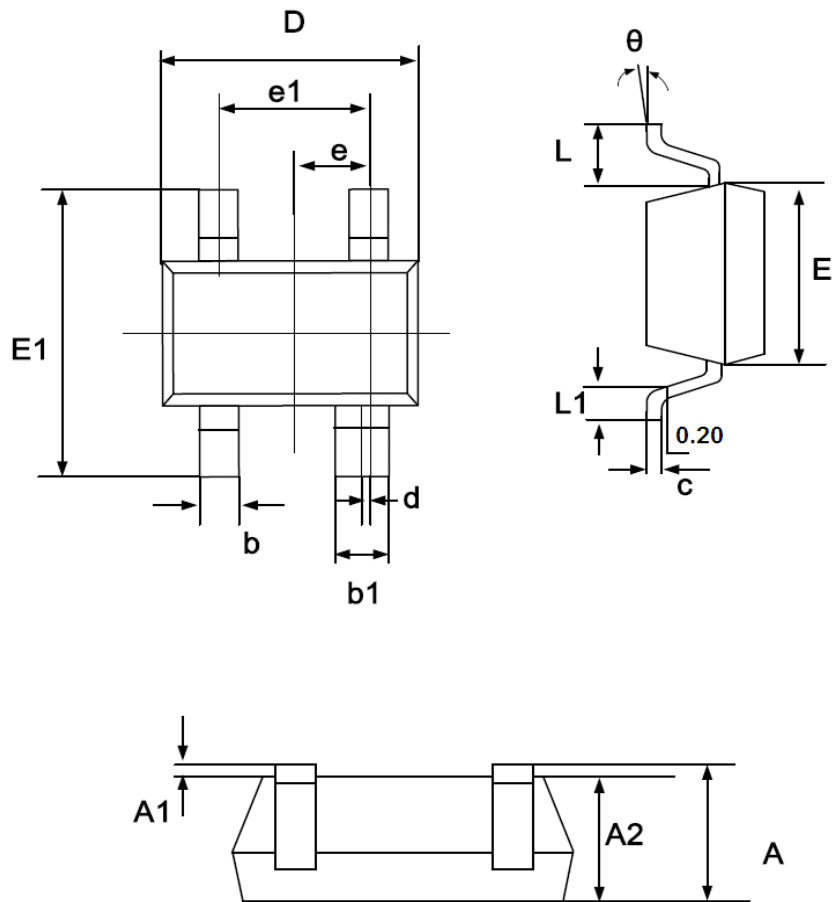

Symbol	Dimensions In Millimeters	
	Min.	Max.
A	0.900	1.100
A1	0.000	0.100
A2	0.900	1.000
b	0.250	0.400
b1	0.350	0.500
c	0.080	0.150
d	0.050 TYP.	
D	2.000	2.200
E	1.150	1.350
E1	2.150	2.450
e	0.650 TYP	
e1	1.200	1.400
L	0.525 REF	
L1	0.260	0.460
θ	0°	8°

© SMTES TECHNOLOGY PTE. LTD.

SMTES cannot assume responsibility for use of any circuitry other than circuitry entirely embodied in a SMTES product. No circuit patent license, copyrights or other intellectual property rights are implied. SMTES reserves the right to make changes to their products or specifications without notice. Customers are advised to obtain the latest version of relevant information to verify, before placing orders, that information being relied on is current and complete.